



Features

- Extremely quiet
- Excellent reliability
- Compact and easy to use
- Easy maintenance
- Long-life, 2-year warranty
- 50% duty cycle

Description

- 5µm air filtration
- Pressure regulator included
- 5-year warranty on receiver

Accessories

- 0.01µm filtration
- Receiver autodrain system
- Condensate bottle

Product Specifications

Model	12-25		
Voltage	V	1x230	1x120
Frequency	Hz	50	60
Motor	HP	0.92	1.08
	kW	0.68	0.79
Displacement	l/min	100	120
Air flow @ 8bar	l/min	64	74
	cfm	2.26	2.61
Max. pressure	bar	8	8
	psi	120	120
Max. current	A	5.8	12.4
Receiver volume	litres	25	25
	gallon	6.6	6.6
Weight	kg	45	45
	lbs	99	99
Noise level	dB(A)/1m	48	48
Duty cycle		50%	50%

Air flow / pressure curve

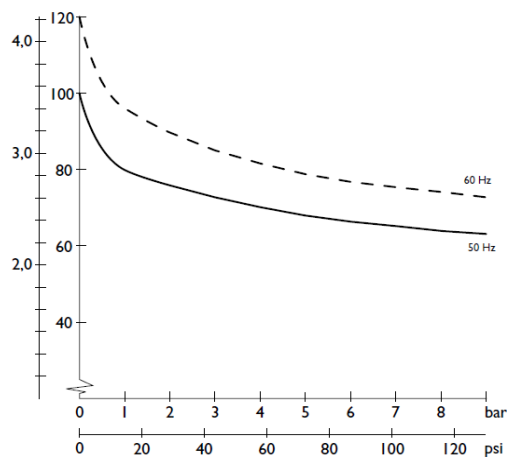

Dimensions - mm / [inches] *

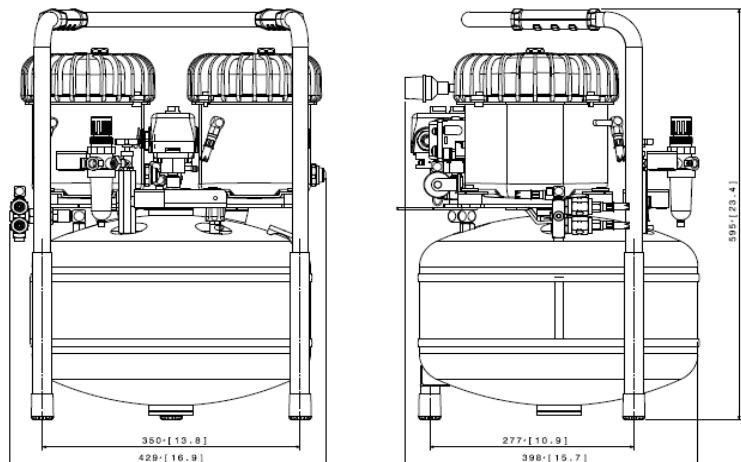

* for unit without accessories